

PART NUMBER	SML-LX2835SISUGSBC	REV.	D
DATE	E.C.N. NUMBER AND REVISION COMMENTS		REV.
03.01.11	E.C.N. #11699.		A
03.28.11	E.C.N. #11707.		B
1.18.12	E.C.N. #11798.		C
06.04.14	E.C.N. #11906.		D

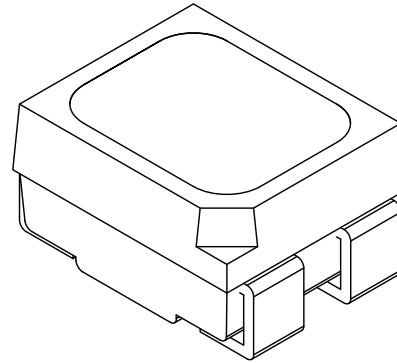
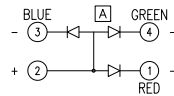
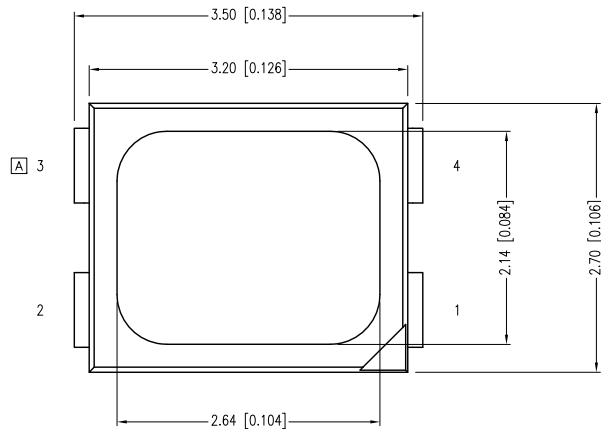

ELECTRO-OPTICAL CHARACTERISTICS $T_A=25^{\circ}\text{C}$ $I_f=20\text{mA}$					
PARAMETER	RED	GREEN	BLUE	UNITS	TEST COND
PEAK WAVELENGTH	632	575	428	nm	
FORWARD VOLTAGE TYP.	2.0	2.2	3.5	$V_f$	
FORWARD VOLTAGE MAX.	2.4	2.4	4.5		
REVERSE VOLTAGE	5.0	5.0	5.0	$V_r$	$I_f=100\mu\text{A}$
AXIAL INTENSITY	80	50	30	mcd	$I_f=20\text{mA}$
VIEWING ANGLE	120	120	120	$2 \times \theta$	
EMITTED COLOR:	RED/GREEN/BLUE				
EPOXY LENS FINISH:	WATER CLEAR LENS				

LIMITS OF SAFE OPERATION AT 25°C PER CHIP			
PARAMETER	COLORS	MAX	UNITS
PEAK FORWARD CURRENT*	(R/G/B)	60/60/70	mA
STEADY CURRENT	(R/G/B)	25/25/30	mA
POWER DISSIPATION		-1.2	W
OPERATING TEMP.		-40 TO +85	°C
STORAGE TEMP.		-40 TO +85	°C
SOLDERING TEMP.		+260	°C
2.0mm FROM BODY			3 SEC. MAX

\*  $t < 10\mu\text{s}$

NOTES:

1. THE POLARITY MARK IS ORIENTED TOWARDS THE TAPE SPROCKET HOLE.
2. 2,000 PER REEL.

CAUTION: MOISTURE SENSITIVE DEVICE  
PER JEDEC LEVEL 2 STANDARDS

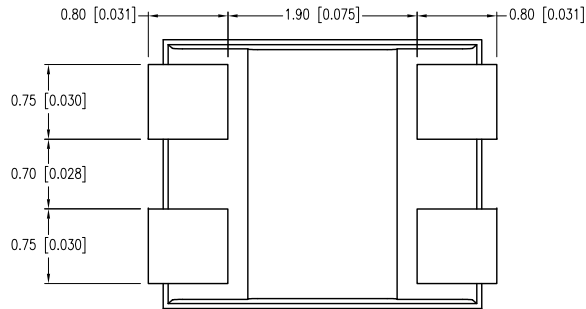
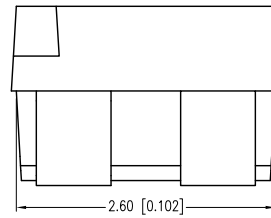
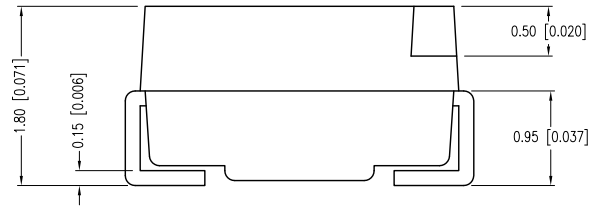

\*UNLESS OTHERWISE SPECIFIED TOLERANCES PER DECIMAL PRECISION ARE: X=±1 (±0.039), X.X=±0.5 (±0.020), X.XX=±0.25 (±0.010), X.XXX=±0.127 (±0.005). LEAD SIZE=±0.05 (±0.002), LEAD LENGTH=±0.75 (±0.030). MIN.= <sup>DECIMAL</sup>PRECISION MAX.= <sup>DECIMAL</sup>PRECISION

**LUMEX**  
Creating LED and LCD Solutions Together™

290 E. HELEN ROAD  
PALATINE, IL 60067-6976  
PHONE: +1.847.359.2790  
FAX: +1.847.359.6538  
WEB: WWW.LUMEX.COM

2.7mm x 3.2mm SML /W REFLECTOR CUP, 632nm/575nm/428nm LED, WATER CLEAR LENS, 2k PER REEL.

\*\*THE SPECIFICATIONS MAY CHANGE AT ANY TIME WITHOUT NOTICE DUE TO NEW MATERIALS OR PRODUCT IMPROVEMENT.\*\*

CONFIDENTIAL INFORMATION  
THE INFORMATION CONTAINED IN THIS DOCUMENT IS THE PROPERTY OF LUMEX INC. EXCEPT AS SPECIFICALLY AUTHORIZED IN WRITING BY LUMEX INC., THE HOLDER OF THIS DOCUMENT SHALL KEEP ALL INFORMATION CONTAINED HEREIN CONFIDENTIAL AND SHALL PROTECT SAME IN WHOLE OR IN PART FROM DISCLOSURE AND DISSEMINATION TO ALL THIRD PARTIES.

DATE:	02.03.11	DRAWN BY:	AB
PAGE:	1 OF 2	CHKD BY:	KF
SCALE:	NTS	APRVD BY:	SS
UNIT:	mm [INCH]		(Pb)

PART NUMBER	SML-LX2835SISUGSBC	REV.	D
DATE	E.C.N. NUMBER AND REVISION COMMENTS		REV.
03.01.11	E.C.N. #11699.		A
03.28.11	E.C.N. #11707.		B
1.18.12	E.C.N. #11798.		C
06.04.14	E.C.N. #11906.		D

LEAD FREE REFLOW PROFILE

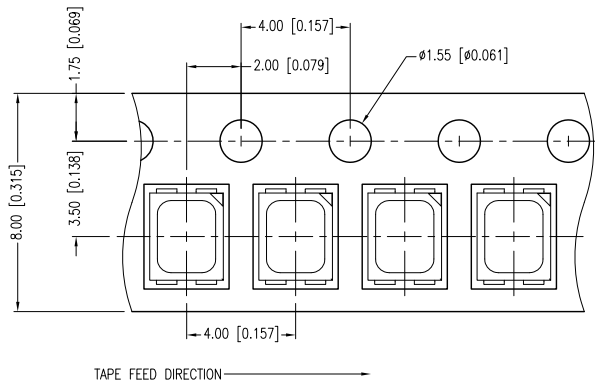
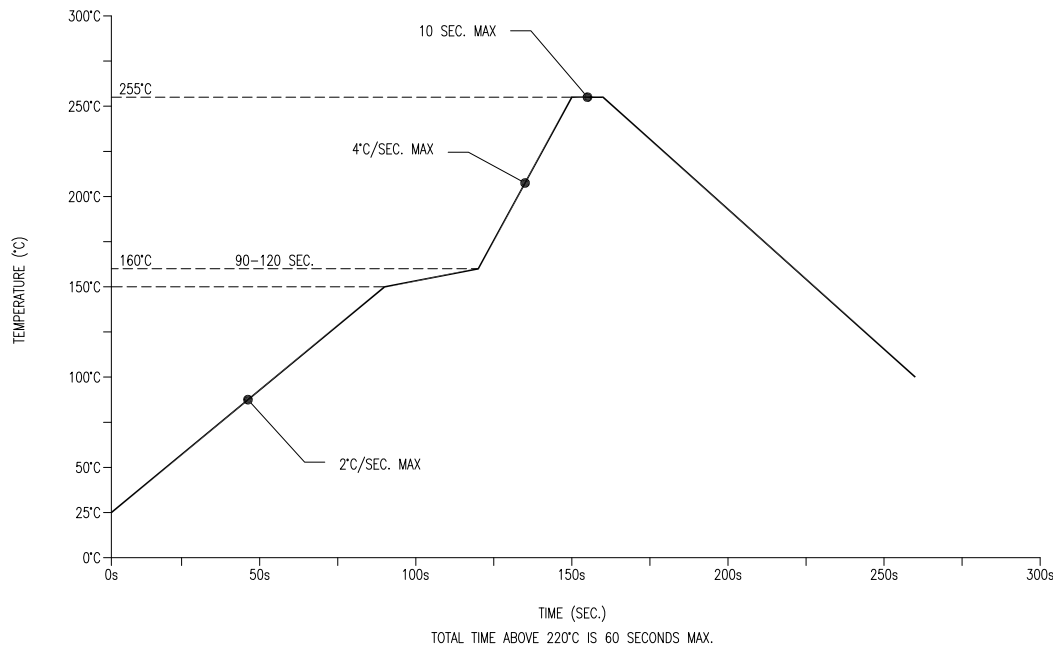

RECOMMENDED SOLDER PAD LAYOUT

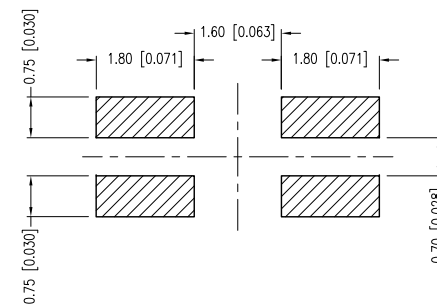

\*UNLESS OTHERWISE SPECIFIED TOLERANCES PER DECIMAL PRECISION ARE: X=±1 (±0.039), X.X=±0.5 (±0.020), X.XX=±0.25 (±0.010), X.XXX=±0.127 (±0.005). LEAD SIZE=±0.05 (±0.002), LEAD LENGTH=±0.75 (±0.030). MIN.= <sup>+0.00</sup> DECIMAL PRECISION -0.00 DECIMAL PRECISION

**LUMEX**  
 Creating LED and LCD Solutions Together™

290 E. HELEN ROAD  
 PALATINE, IL 60067-6976  
 PHONE: +1.847.359.2790  
 FAX: +1.847.359.6538  
 WEB: WWW.LUMEX.COM

2.7mm x 3.2mm SML /W REFLECTOR CUP, 632nm/575nm/428nm LED, WATER CLEAR LENS, 2k PER REEL.

\*\*THE SPECIFICATIONS MAY CHANGE AT ANY TIME WITHOUT NOTICE DUE TO NEW MATERIALS OR PRODUCT IMPROVEMENT.\*\*

CONFIDENTIAL INFORMATION  
 THE INFORMATION CONTAINED IN THIS DOCUMENT IS THE PROPERTY OF LUMEX INC. EXCEPT AS SPECIFICALLY AUTHORIZED IN WRITING BY LUMEX INC., THE HOLDER OF THIS DOCUMENT SHALL KEEP ALL INFORMATION CONTAINED HEREIN CONFIDENTIAL AND SHALL PROTECT SAME IN WHOLE OR IN PART FROM DISCLOSURE AND DISSEMINATION TO ALL THIRD PARTIES.

DATE: 02.03.11	DRAWN BY: AB
PAGE: 2 OF 2	CHKD BY: KF
SCALE: NTS	APRVD BY: SS
UNIT: mm [INCH]	Ⓟ