

4

3

2

1

THIS DRAWING IS UNPUBLISHED. RELEASED FOR PUBLICATION ,19 .  
 © COPYRIGHT 19 BY AMP INCORPORATED. ALL RIGHTS RESERVED.

LOC	DIST	REVISIONS					
		P	LTR	DESCRIPTION	DATE	DWN	APVD
G	16			INITIAL RELEASE	02/15/96	KW	JK
				ADDED MATL & FINISH TO TITLE BLOCK	03/06/96	KW	JK
				REV PER ECN #OK50-0015-96	09/23/96	KW	JK
				REV PER ECN OK20-0007-98	06/24/98	KL	JS
				REV PER EC# OK40-0209-00	9-26-00	PC	MH

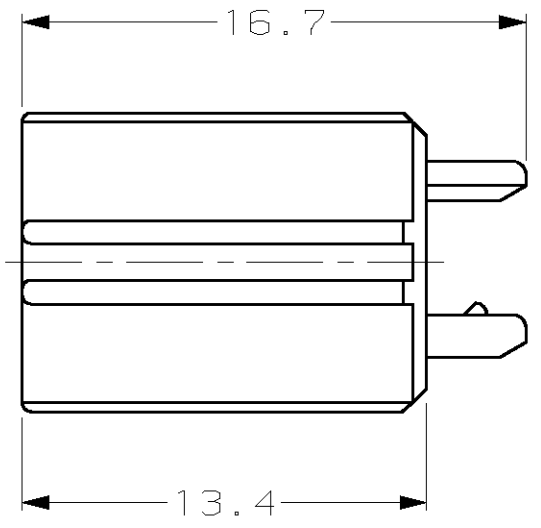
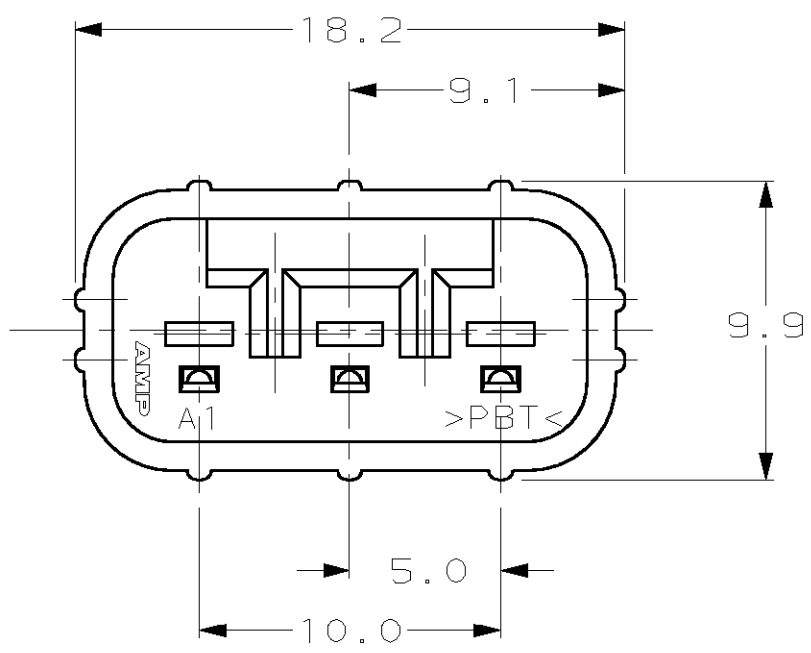
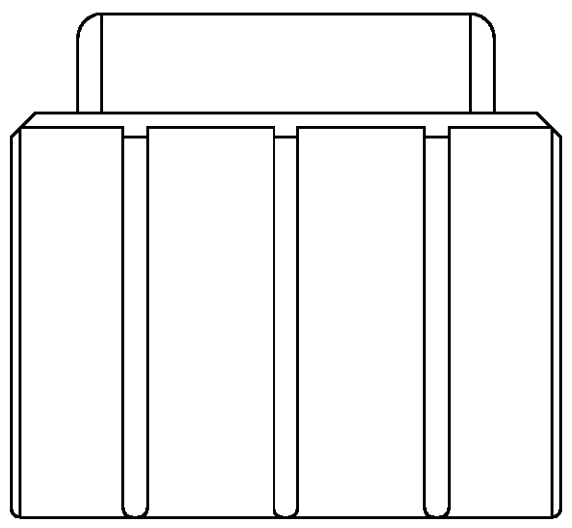

184196-1  
PART NUMBER

<small>THIS DRAWING IS A CONTROLLED DOCUMENT FOR AMP INCORPORATED. IT IS SUBJECT TO CHANGE AND THE CONTROLLING ENGINEERING ORGANIZATION SHOULD BE CONTACTED FOR THE LATEST REVISION.</small>		DWN K. WISE 02/15/96	AMP Incorporated Harrisburg, PA 17105-3608
DIMENSIONS: mm		CHK J. KUNKLE 03/01/96	
		APVD J. KUNKLE 03/01/96	NAME LOCK PLATE, CAP HSG, SSC 3 POSN
TOLERANCES UNLESS OTHERWISE SPECIFIED: 0 PLC ±- 1 PLC ±0.3 2 PLC ±- 3 PLC ±- 4 PLC ±- ANGLES ±- FINISH		PRODUCT SPEC -	SIZE A3
MATERIAL PBT-GF15		APPLICATION SPEC -	CAGE CODE 00779
		WEIGHT -	DRAWING NO C-184196
		CUSTOMER DRAWING	SCALE 2:1
			SHEET 1 OF 1
			REV C