

DO NOT SCALE FROM THIS PRINT

SDX-1XX-XX-XX-X-X

BODY SPECIFICATION

SDL: SLIM (USE HSDL-XX)
(SEE NOTE 5)

(ONLY AVAILABLE FOR LEAD STYLES -10, -11, -12, -19, -30, -31, -32, & -39)

(LEAVE BLANK FOR SD, USE DSB-36)

(NOT AVAILABLE FOR LEAD STYLES -10, -11, -12, -19, -30, -31, -32, & -39)

OPTION

-N: NON-FLUSH
(SEE NOTE 6)
(NOT AVAILABLE ON LEAD STYLES -5A, -7, -21A, -21C, & -29)

OPTION

-L: LOCKING LEAD
(ONLY AVAILABLE WITH LEAD STYLES -2 & -22)
(ONLY AVAILABLE WITH -T PLATING)

LEAD STYLE

(SEE SOCKET SPECIFICATION, TABLES 1 & 2)

PLATING SPECIFICATION

-G: 10µ" GOLD ON CONTACT,
10µ" GOLD ON SHELL
(SPECIFY 'GG' IN SOCKET SUFFIX 'XX')

-T: 30µ" GOLD ON CONTACT,
MATTE TIN ON SHELL
(-GT OPTION NOT AVAILABLE ON LEAD STYLE -7)
(SPECIFY 'GT' IN SOCKET SUFFIX 'XX')

-TT: MATTE TIN ON CONTACT,
MATTE TIN ON SHELL
(NOT AVAILABLE ON LEAD STYLES -7 AND -21A THRU -39)
(SPECIFY 'TT' IN SOCKET SUFFIX 'XX')

-S: 10µ" SELECTIVE GOLD ON CONTACT,
MATTE TIN ON SHELL
(ONLY AVAILABLE ON LEAD STYLES -2 & -22)
(NOT AVAILABLE ON SDL-)
(FOR LOCKING LEAD OPTION, USE SC-1L1-GT)
(SPECIFY 'ST' IN SOCKET SUFFIX 'XX')

No OF POSITIONS
-01 THRU -36
(PER ROW)

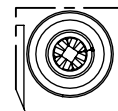

DETAIL 'A'
SCALE 6:1
(SEE TABLE 1 & NOTE 7)

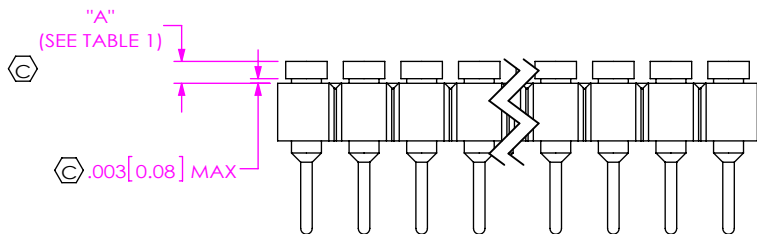
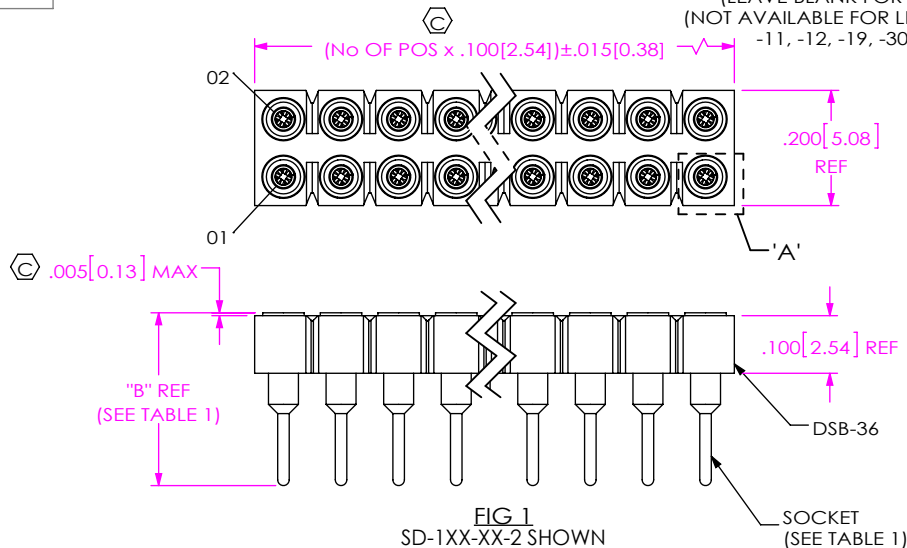

FIG 2
SD-1XX-XX-2-N SHOWN
(SEE NOTE 6)
(SAME AS FIG 1, DIFFERENT AS SHOWN)

NOTES:

- ⊗ REPRESENTS A CRITICAL DIMENSION.
- MAXIMUM CUT FLASH: .005[0.13] IN ALL AREAS EXCEPT BAR BREAK OFF AREA; .012[0.31] IN BAR BREAK OFF AREA
- MINIMUM PUSHOUT FORCE: 5 LB
- MAXIMUM ALLOWABLE BOW: SD: 2-10 POS: .006", 11-19 POS: .008" IN/IN, 20-36 POS: .018" IN/IN;
SDL: 2-10 POS: .006", 11-19 POS: .015" IN/IN, 20-36 POS: .030" IN/IN.
- FOR A ONE POSITION SDL, CUT SL-132 TO 2 POSITIONS.
- FOR -SD WITH -N OPTION, INSERT PIN ON SIDE WITH SMALLER HOLE, OPPOSITE COUNTERBORE.
- OPERATOR MUST VERIFY CORRECT PIN BY CHECKING THE NUMBER OF CLIPS.
- PLATING OPTION -GT NOT AVAILABLE.
- PLATING OPTION -GG NOT AVAILABLE.
- POSITIONS 1 - 4 AND ANY BODY/LEAD STYLES NOT LISTED IN THE TUBE TABLE TO BE PACKAGED IN BULK.

TABLE 1 - SD LEAD STYLES

LEAD STYLE	SOCKET	"A" (-N OPTION ONLY)		"B" (PIN LENGTH)	No OF FINGER CLIPS (SEE NOTE 7)
		MIN	MAX		
-1A	SC-1W1-XX-2	N/A	.038 [0.97]	.563 [14.30]	4
-1B	SC-1W1-XX-1	N/A	.038 [0.97]	.703 [17.86]	4
-1C	SC-1W1-XX-3	N/A	.038 [0.97]	.453 [11.51]	4
-2	SC-1P1-XX	.025 [0.64]	.038 [0.97]	.300 [7.62]	4
*-5A	SC-2P1-XX	N/A	N/A	.703 [17.86]	4
-7	SC-1P3-XX	.025 [0.64]	.038 [0.97]	.600 [15.24]	4
-18	SC-6P1-XX	.025 [0.64]	.038 [0.97]	.353 [8.97]	4
-21A	EZ-1W1-XX-2	N/A	N/A	.553 [14.05]	6
-21B	EZ-1W1-XX-1	N/A	N/A	.703 [17.86]	6
-21C	EZ-1W1-XX-3	N/A	N/A	.453 [11.51]	6
-22	EZ-1P1-XX	.025 [0.64]	.038 [0.97]	.300 [7.62]	6
-29	EZ-2P2-XX	N/A	N/A	.703 [17.86]	6
-38	EZ-6P1-XX	.025 [0.64]	.038 [0.97]	.353 [8.97]	6

* = AVAILABLE TO EXISTING CUSTOMERS ONLY

UNLESS OTHERWISE SPECIFIED, DIMENSIONS ARE IN INCHES.

TOLERANCES ARE:

DECIMALS ANGLES
.XX: ±.01 [0.3] 2°
.XXX: ±.005 [0.13]
.XXXX: ±.0020 [0.051]

PROPRIETARY NOTE

THIS DOCUMENT CONTAINS CONFIDENTIAL AND PROPRIETARY INFORMATION AND ALL DESIGN, MANUFACTURING, REPRODUCTION, USE, PATENT RIGHTS AND SALES RIGHTS ARE EXPRESSLY RESERVED BY SAMTEC, INC. THIS DOCUMENT SHALL NOT BE DISCLOSED, IN WHOLE OR PART, TO ANY UNAUTHORIZED PERSON OR ENTITY NOR REPRODUCED, TRANSFERRED OR INCORPORATED IN ANY OTHER PROJECT IN ANY MANNER WITHOUT THE EXPRESS WRITTEN CONSENT OF SAMTEC, INC.



520 PARK EAST BLVD, NEW ALBANY, IN 47150
PHONE: 812-944-6733 FAX: 812-948-5047
e-Mail: info@SAMTEC.com code 55322

MATERIAL: DO NOT SCALE DRAWING SHEET SCALE: 3:1

INSULATOR: LCP or NYLON
COLOR: BLACK
SOCKET: BeCu/BRASS
BRASS

DESCRIPTION: SOCKET STRIP ASSEMBLY

DWG. NO. SDX-1XX-XX-XX-X-X

BY: J. BROWNING 07/27/2015 SHEET 1 OF 2

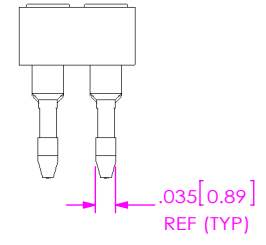
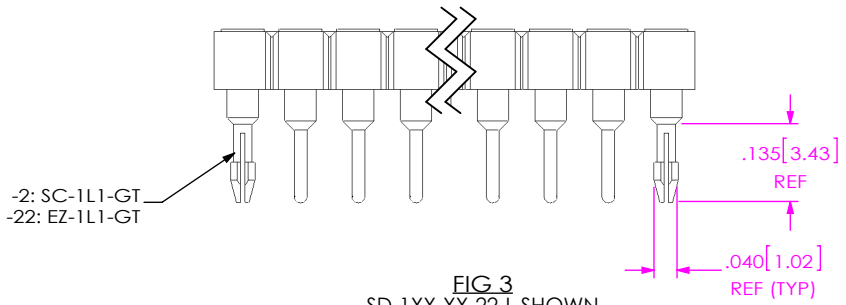

FIG 3
SD-1XX-XX-22-L SHOWN
(ONLY AVAILABLE IN LEAD STYLES -2 & -22)
(SAME AS FIG 1, DIFFERENT AS SHOWN)

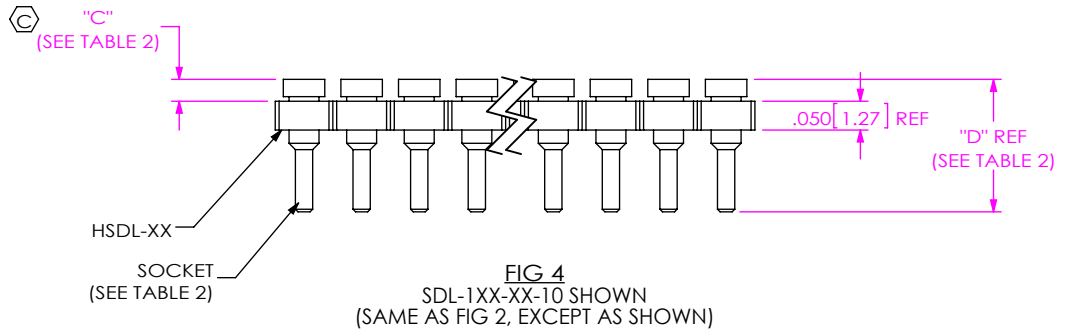
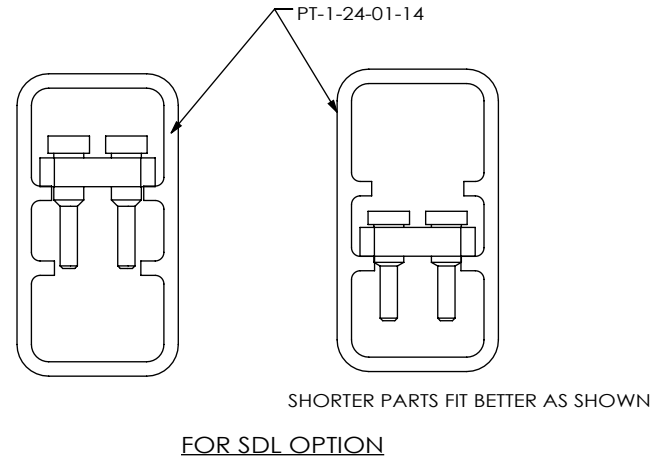
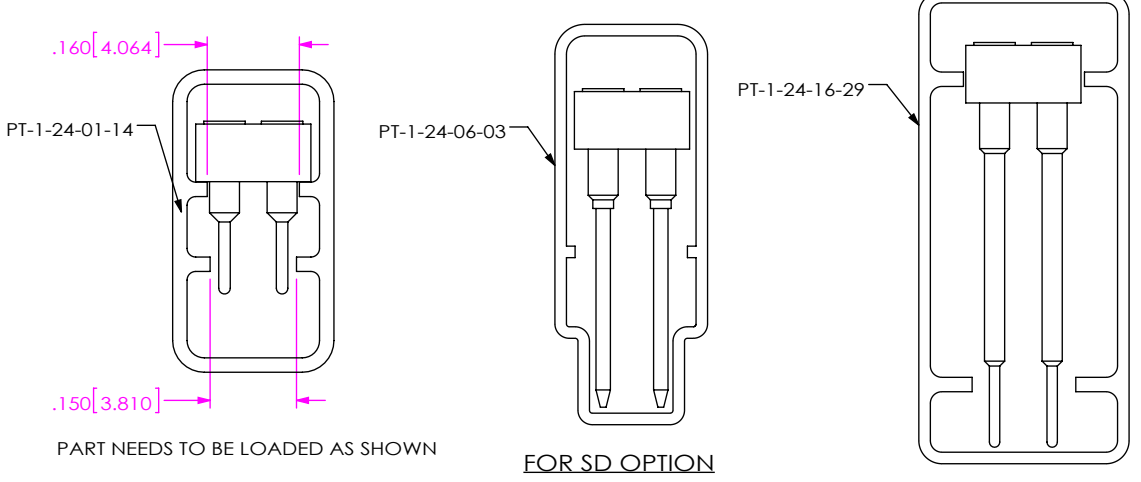

FIG 4
SDL-1XX-XX-10 SHOWN
(SAME AS FIG 2, EXCEPT AS SHOWN)

LEAD STYLE	SOCKET	"C"		"D" (PIN LENGTH)	No OF FINGER CLIPS (SEE NOTE 7)
		MIN	MAX		
-10	SC-3P1-XX	.025 [0.64]	.038 [0.97]	.230 [5.84]	4
-11	SC-4P1-XX	.015 [0.38]	.028 [0.71]	.240 [6.10]	4
-12	SC-5P1-XX	.015 [0.38]	.028 [0.71]	.190 [4.83]	4
-19	SC-8P1-XX	.005 [0.13]	.016 [0.41]	.165 [4.19]	4
-30	EZ-3P1-XX	.025 [0.64]	.038 [0.97]	.230 [5.84]	6
-31	EZ-4P1-XX	.015 [0.38]	.028 [0.71]	.240 [6.10]	6
-32	EZ-5P1-XX	.015 [0.38]	.028 [0.71]	.190 [4.83]	6
-39	EZ-8P1-XX	.005 [0.13]	.016 [0.41]	.165 [4.19]	6



PACKAGING VIEWS
(SEE NOTE 10 & TABLE 3)

BODY STYLE	LEAD STYLE	TUBE	PLUG
-SD	-1C, -2, -2-L, -18, -21C, -22, -22-L, -38	PT-1-24-01-14	TP-03
	-1A, -21A, -7	PT-1-24-06-03	TP-07
	-29	PT-1-24-16-29	TP-03
-SDL	ALL	PT-1-24-01-14	TP-03

PROPRIETARY NOTE
THIS DOCUMENT CONTAINS CONFIDENTIAL AND PROPRIETARY INFORMATION AND ALL DESIGN, MANUFACTURING, REPRODUCTION, USE, PATENT RIGHTS AND SALES RIGHTS ARE EXPRESSLY RESERVED BY SAMTEC, INC. THIS DOCUMENT SHALL NOT BE DISCLOSED, IN WHOLE OR PART, TO ANY UNAUTHORIZED PERSON OR ENTITY NOR REPRODUCED, TRANSFERRED OR INCORPORATED IN ANY OTHER PROJECT IN ANY MANNER WITHOUT THE EXPRESS WRITTEN CONSENT OF SAMTEC, INC.

DO NOT SCALE DRAWING
SHEET SCALE: 3:1

520 PARK EAST BLVD, NEW ALBANY, IN 47150
PHONE: 812-944-6733 FAX: 812-948-5047
e-Mail info@SAMTEC.com code 55322

DESCRIPTION:
SOCKET STRIP ASSEMBLY

DWG. NO.
SDX-1XX-XX-XX-X-X

BY: J. BROWNING 07/27/2015 SHEET 2 OF 2